

HOSEBED CAPACITIES
 ① 1000' OF 5.00" D.J. POLY HOSE
 ② 600' OF 2.50" D.J. POLY HOSE

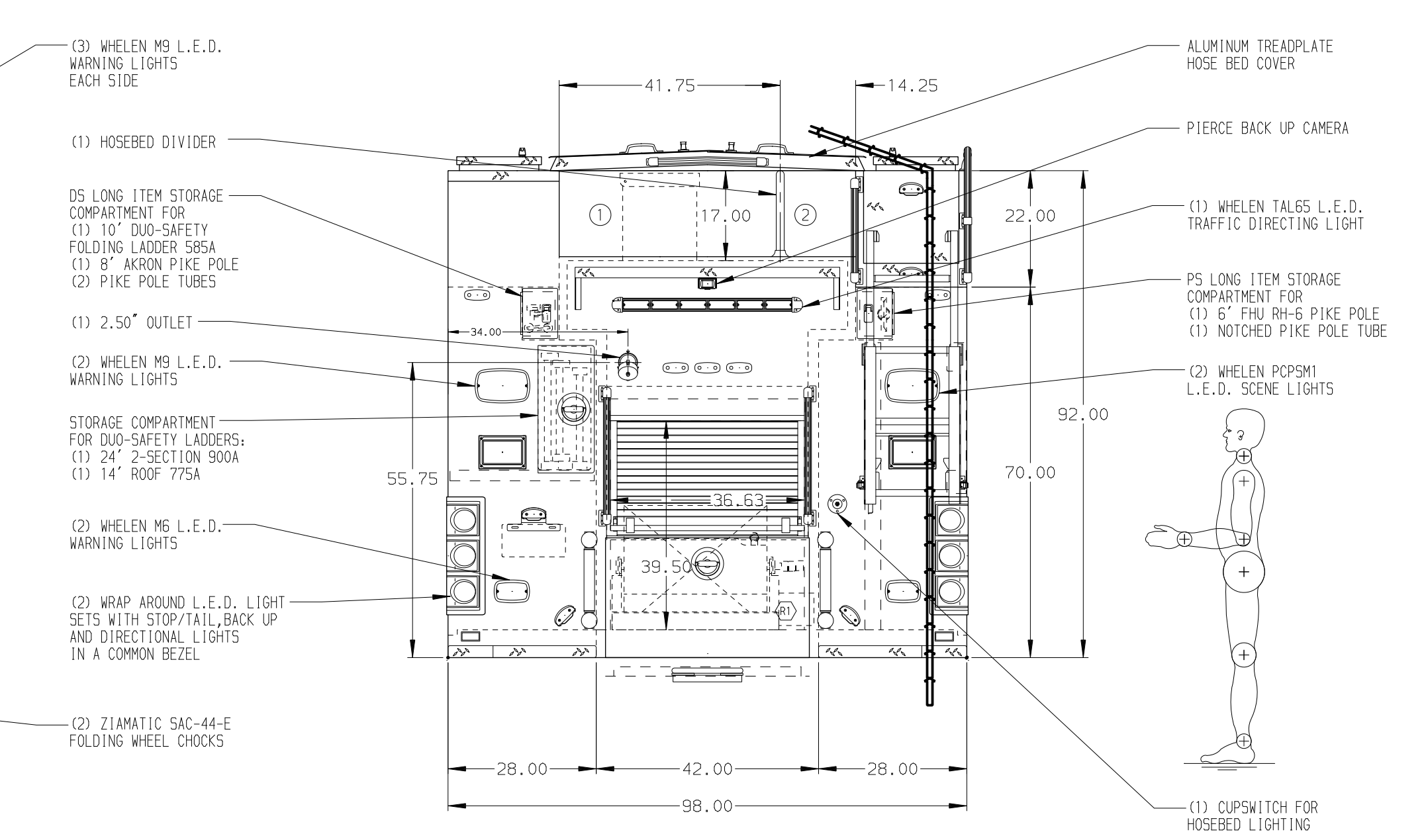
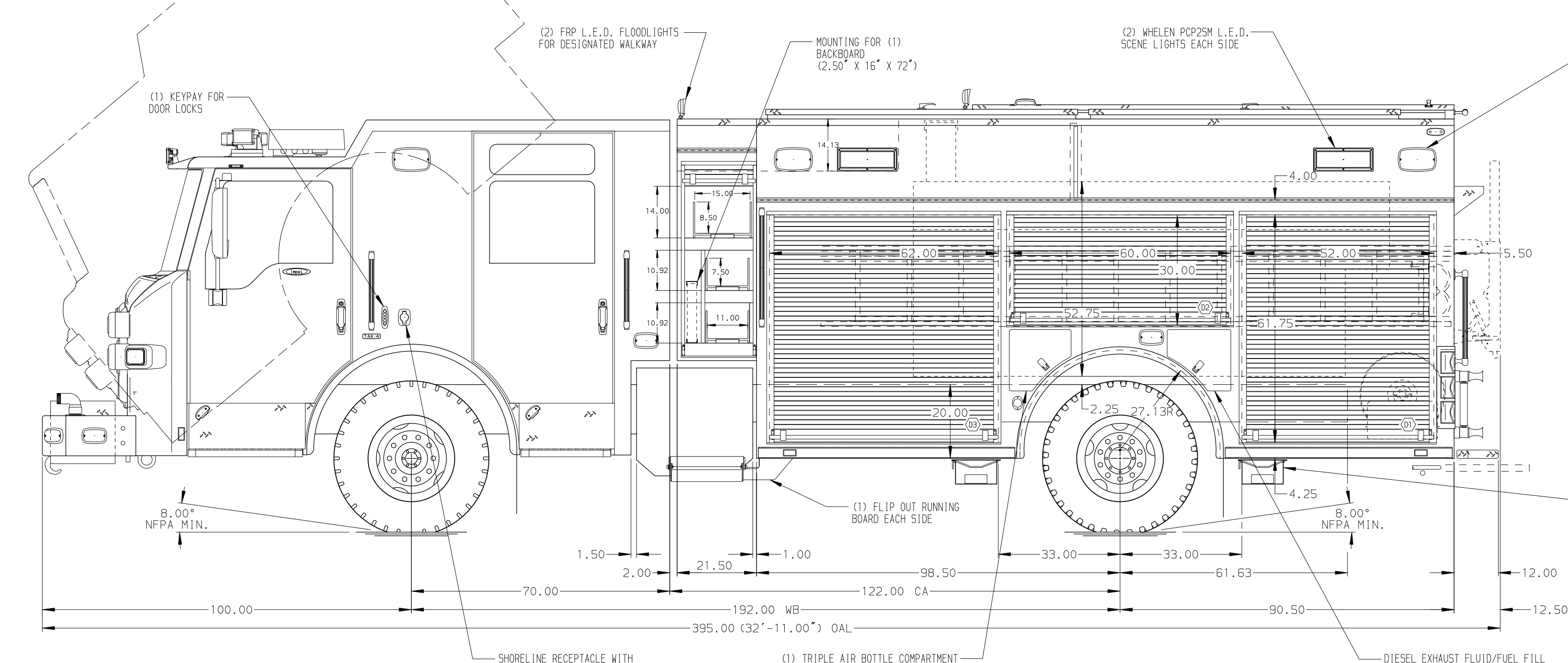

ALUMINUM BODY

SIDE ROLL AND FRONTAL IMPACT PROTECTION

NOTE
 DIMENSIONS SHOWN ARE APPROXIMATE AND ARE SUBJECT TO MINOR DEVIATIONS AS MAY OCCUR OR BE NECESSARY IN CONSTRUCTION.
 MINOR DETAILS NOT SHOWN.

- BATTERY CHARGER LOCATED BEHIND DRIVERS SEAT
- BATTERY CHARGE INDICATOR LOCATED NEAR D.S. SEAT RISER WITH BRACKET
- AIR OUTLET W/ SHUT OFF VALVE LOCATED ON DS PUMP PANEL
- GROVER TRAIN HORN MOUNTED BEHIND FRONT BUMPER
- ONE ADJUSTABLE FULL WIDTH/FULL DEPTH SHELF IN COMPARTMENTS D1, D3, & P2; TWO IN P1 & P3
- ONE FLOOR MOUNTED SLIDE-OUT TRAY COMPARTMENTS P1 & P3
- ONE SWING-OUT ALUMINUM TOOL BOARD IN COMPARTMENT D2
- ONE TOOLBOARD ADDED TO SLIDE OUT TRAY IN COMPARTMENT P1
- MOUNTING FOR LITTLE GIANT LADDER MODEL 17 LOCATED IN COMPARTMENT P3
- ONE VERTICAL PARTITION LOCATED IN COMPARTMENT P1
- ALUMINUM PEGBOARD LOCATED ON BACK WALL OF COMPARTMENTS D2 & D3
- ONE 120V DUPLEX RECEPTACLE LOCATED IN COMPARTMENT P1 & CAB
- HANNAY BOOSTER REEL MODEL EP34-23-24 LOCATED IN COMPARTMENT R1 WITH CAPACITY FOR 200' OF 1.00" BOOSTER HOSE

REV	DATE	BY	CH	IMPEL
02FEB17	COL	SHA		CHASSIS DATA
09DEC16	COL	SHA		MAKE
06DEC16	COL	SHA		PIERCE
03NOV16	COL	SHA		MODEL

		JOB NO.	30324 01-07
		SCALE	1:24
TITLE	1500-D-1000 GALLON POLY WATERTANK, 189" PUC RESCUE (3) XLAYS, DELUGE, LADDERS THRU DRIVERS SIDE BODY	DRAWN BY	COL
FOR	ODESSA FIRE DEPARTMENT ODESSA, TEXAS	CHECKED BY	JBL
DWG NO.	30324AD	SHEET SIZE	D
		SHEET NO.	1 OF 1

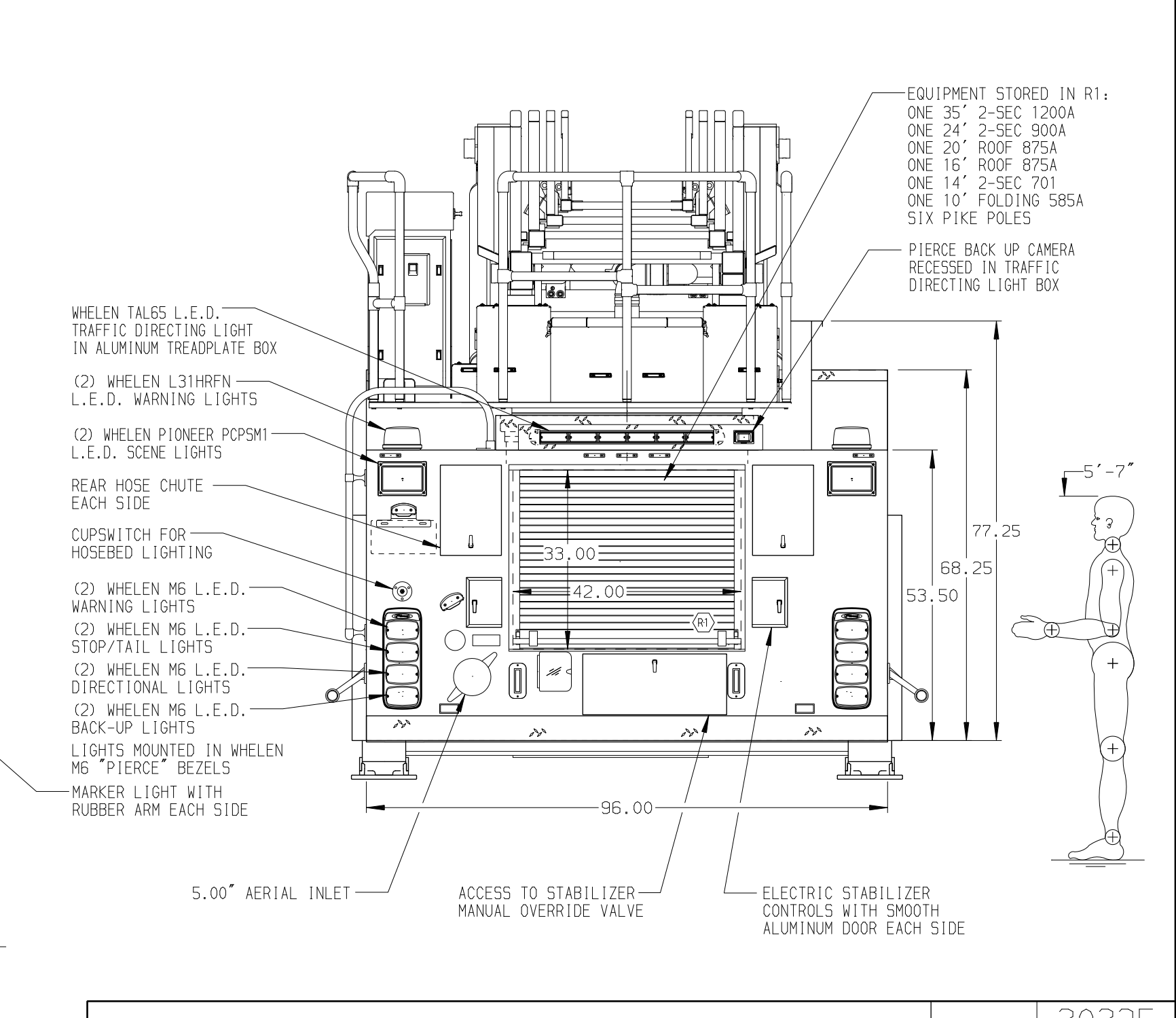
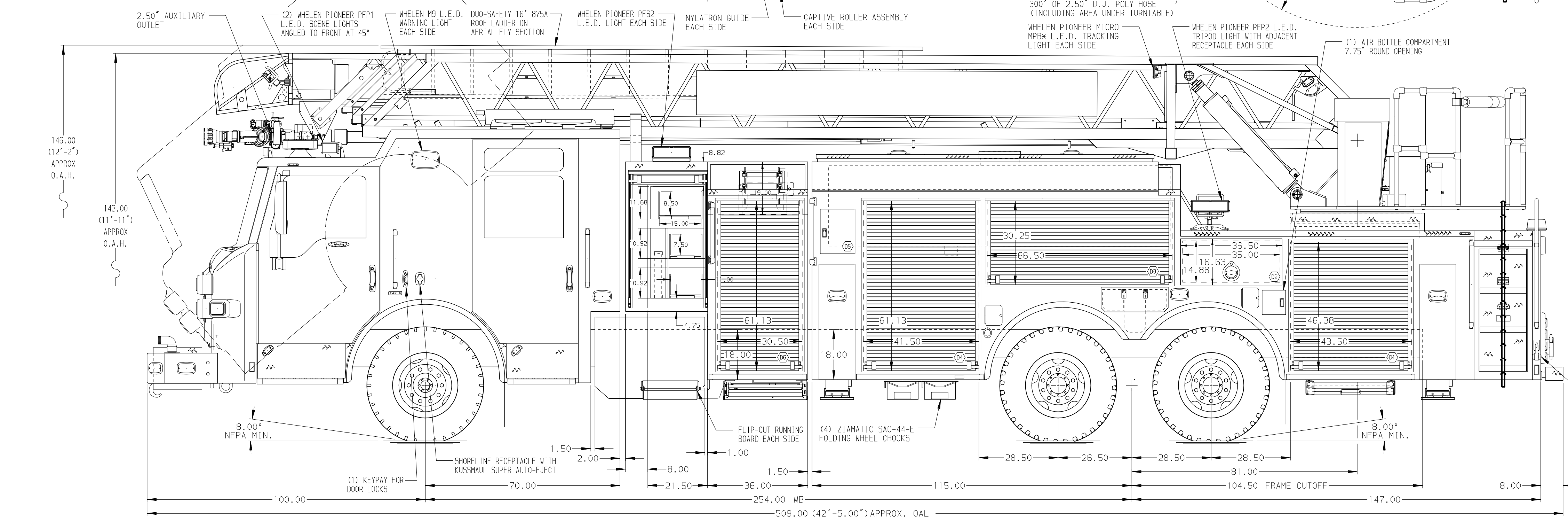
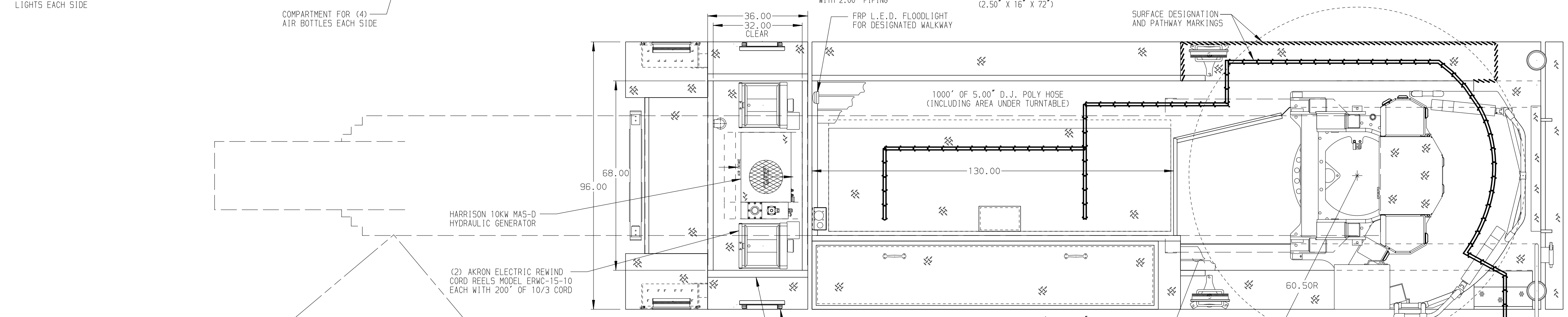
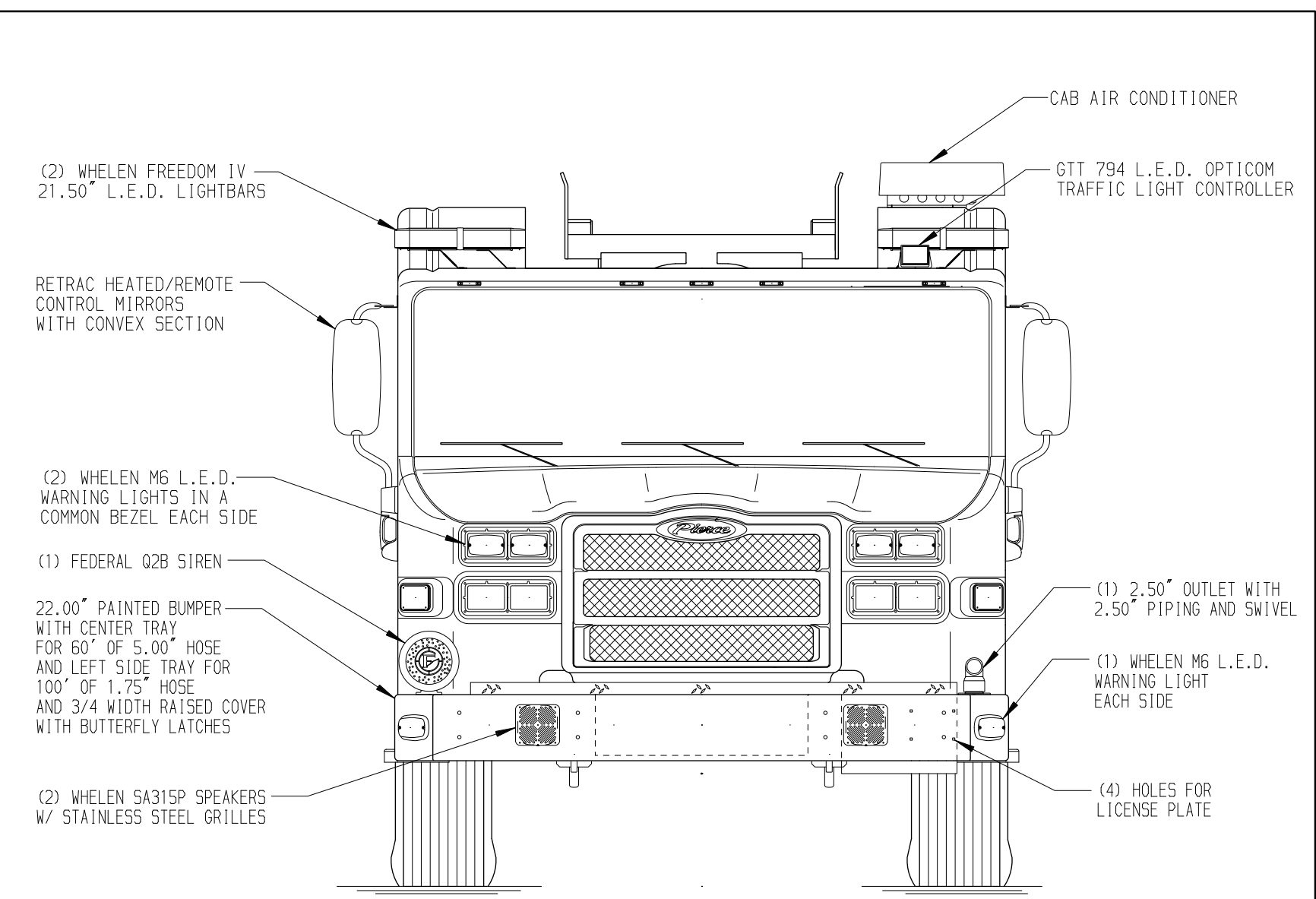
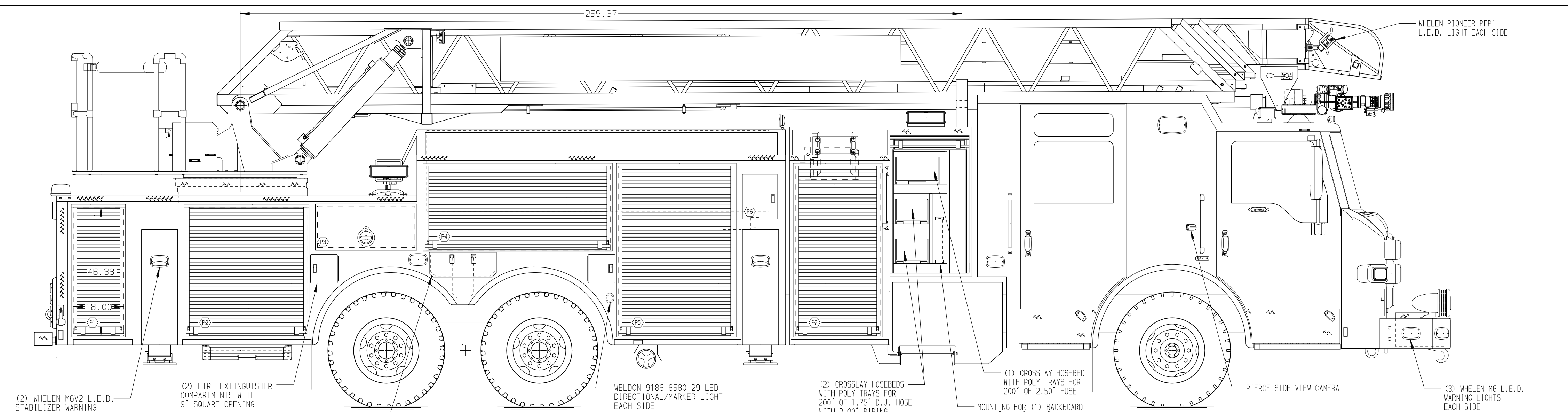

ALUMINUM BODY

(SIDE ROLL AND FRONTAL IMPACT PROTECTION)

NOTE
DIMENSIONS SHOWN ARE APPROXIMATE AND ARE SUBJECT TO MINOR DEVIATIONS AS MAY OCCUR OR BE NECESSARY IN CONSTRUCTION. MINOR DETAILS NOT SHOWN.

- BATTERY CHARGER MOUNTED BEHIND DRIVER'S SIDE SEAT ONE EMS COMPARTMENT WALL
- BATTERY CHARGE INDICATOR LOCATED NEAR D.S. SEAT RISER WITH BRACKET
- ONE FLOOR MOUNTED SLIDE-OUT TRAY IN COMPARTMENTS D1,P5,P7
- ONE SWING-OUT TOOL BOARD WITH PEGBOARD PATTERN IN COMPARTMENT P4
- ONE ADJUSTABLE FULL WIDTH/FULL DEPTH SHELF IN COMPARTMENTS D1,D4,P1,P2,TWO IN P5,P7
- CIRCUIT BREAKER PANEL IN COMPARTMENT D5
- AIR OUTLET WITH SHUT-OFF VALVE LOCATED ON DS PUMP PANEL
- 120V POWER TO AERIAL TIP
- FIRE RESEARCH 3-WAY INTERCOM SYSTEM BETWEEN AERIAL TIP,PUMP PANEL & TURNTABLE
- AERIAL PEDESTAL RAISED 3.00"
- LYFEPULLEY RESCUE SYSTEM AT AERIAL TIP
- COLLISION AVOIDANCE CONTROL SYSTEM ON AERIAL DEVICE
- DUAL L.E.D. LIGHT STRIPS LOCATED IN HOSE BED
- DRIP PAN GUARD FOR EACH BODY COMPARTMENT ROLL-UP DOOR
- ONE ADJUSTABLE TILTING SLIDE-OUT TRAY IN COMPARTMENTS D3,D4
- ONE VERTICAL PARTITION IN COMPARTMENT D4
- ALUMINUM PEGBOARD WITH TRACKS ON THE REAR WALL OF COMPARTMENT P4
- GROVER TRAIN HORN MOUNTED BEHIND FRONT BUMPER
- TWO VELCRO STRAPS IN COMPARTMENT D4 FROM PARTITION TO REAR BULKHEAD WALL

REV	DATE	BY	CH	MAKE
01FEB17		SHU	SHA	PIERCE
30NOV16		SHU	TWH	PIERCE
13SEP16		SHU	JBL	PIERCE

		JOB NO.	30325-01-03
		SCALE	1:24
TITLE	105 AERIAL LADDER & BODY ASSEMBLY	DRAWN BY	SHU
FOR	500 GALLON WATER TANK	CHECKED BY	JBL
	ODESSA FIRE DEPARTMENT	SHEET SIZE	D
	ODESSA, TEXAS	SHEET NO.	1 OF 1
DWG NO.	30325AD		

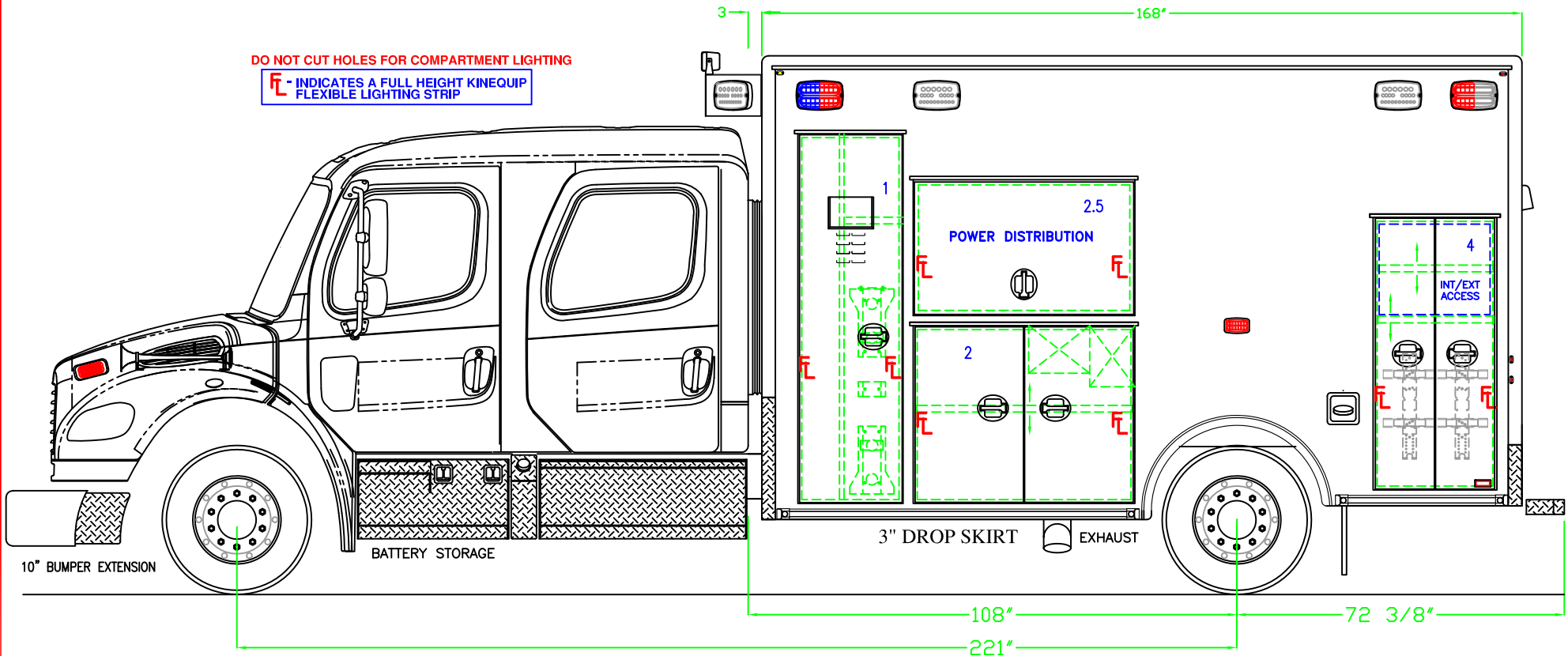

ODESSA FIRE DEPARTMENT FREIGHTLINER ULTRAMEDIC WALK-THROUGH



DOOR NO.	INTERIOR DIMENSIONS			NOTES	DOOR NO.	DOOR DIMENSIONS		NOTES
	HEIGHT	WIDTH	DEPTH			HEIGHT	WIDTH	
1	80.00"	23.25"	22.50"	FIXED DIVDER & SHELF, O2 STORAGE				PROPRIETARY AND CONFIDENTIAL THIS INFORMATION CONTAINED IN THIS DRAWING IS THE SOLE PROPERTY OF ROAD RESCUE INC. ANY REPRODUCTION IN PART OR AS A WHOLE WITHOUT THE WRITTEN PERMISSION OF ROAD RESCUE IS PROHITTED. DETAILS ARE CONCEPTUAL ONLY. LAYOUT AND ALL DIMENSIONS ARE APPROXIMATE AND ARE SUBJECT TO MODIFICATION BY DESIGN ENGINEERING.
2	38.50"	49.25"	21.62"	(1) ADJ. SHELF				
2.5	30.00"	49.25"	7.00"	POWER DISTRIBUTION				
4	59.50"	27.38"	21.62"	(2) ADJ. SHELVES, SCBA STORAGE, INT/EXT ACCESS				

Road Rescue 2737 N. FORSYTH RD
WINTER PARK, FL 32792
www.roadrescue.com PHONE 800-932-7077 FAX 800-513-2688
DRAWN BY DATE REVISION 1 REVISION 2 REVISION 4 REVISION 6
RRS 06/07/2018

STREETSIDE EXTERIOR DETAIL

BID NUMBER
 **218153** 



ODESSA FIRE DEPARTMENT FREIGHTLINER ULTRAMEDIC WALK-THROUGH



DO NOT CUT HOLES FOR COMPARTMENT LIGHTING

FL - INDICATES A FULL HEIGHT KINEQUIP FLEXIBLE LIGHTING STRIP

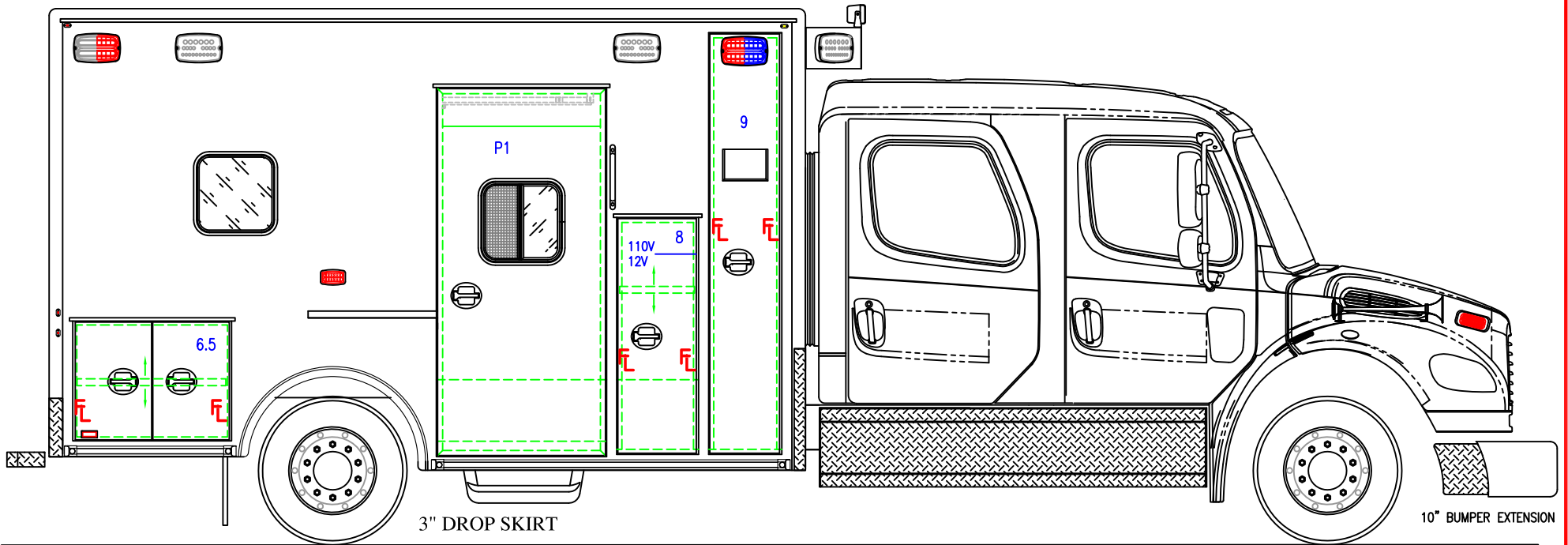

DOOR NO.	INTERIOR DIMENSIONS			NOTES	DOOR NO.	DOOR DIMENSIONS		NOTES
	HEIGHT	WIDTH	DEPTH			HEIGHT	WIDTH	
6.5	25.75"	35.25"	17.25"	(1) ADJ. SHELF	8	51.50"	18.25"	RIGHT STACK/ALS ACCESS, LOWER #8 STORAGE
9	92.50"	16.25"	21.50"	BACKBOARD STORAGE	P1	72.75"	30.00"	SLIDING TINTED WINDOW 18" X 18"

DETAILS ARE CONCEPTUAL ONLY. LAYOUT AND ALL DIMENSIONS ARE APPROXIMATE AND ARE SUBJECT TO MODIFICATION BY DESIGN ENGINEERING.

PROPRIETARY AND CONFIDENTIAL
THIS INFORMATION CONTAINED IN THIS DRAWING IS THE SOLE PROPERTY OF ROAD RESCUE INC. ANY REPRODUCTION IN PART OR AS A WHOLE WITHOUT THE WRITTEN PERMISSION OF ROAD RESCUE IS PROHIBITED.

Road Rescue 2737 N. FORSYTH RD
WINTER PARK, FL 32792

CURBSIDE EXTERIOR DETAIL

BID NUMBER
218153

www.roadrescue.com PHONE 800-932-7077 FAX 800-513-2688
DRAWN BY RRS DATE 06/07/2018 REVISION 1 REVISION 2 REVISION 4 REVISION 6 SHEET 2 OF 13

NOTE: THIS DRAWING IS SUBJECT TO CHANGE PENDING ROAD RESCUE, INC. PRODUCTION ENGINEERING APPROVAL. © ROAD RESCUE, INC. ALL RIGHTS RESERVED.

ODESSA FIRE DEPARTMENT FREIGHTLINER ULTRAMEDIC WALK-THROUGH

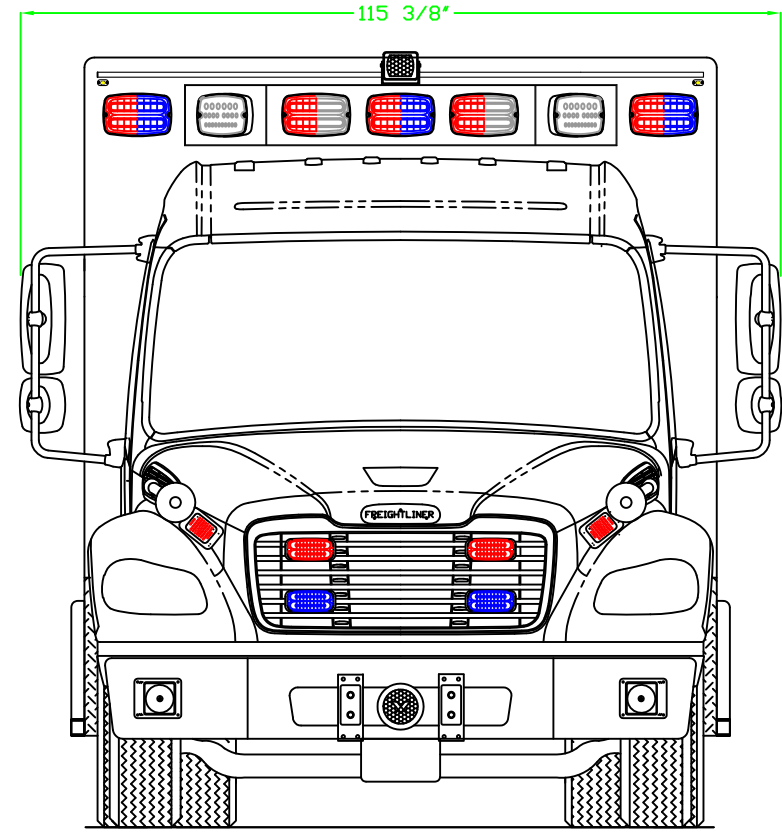
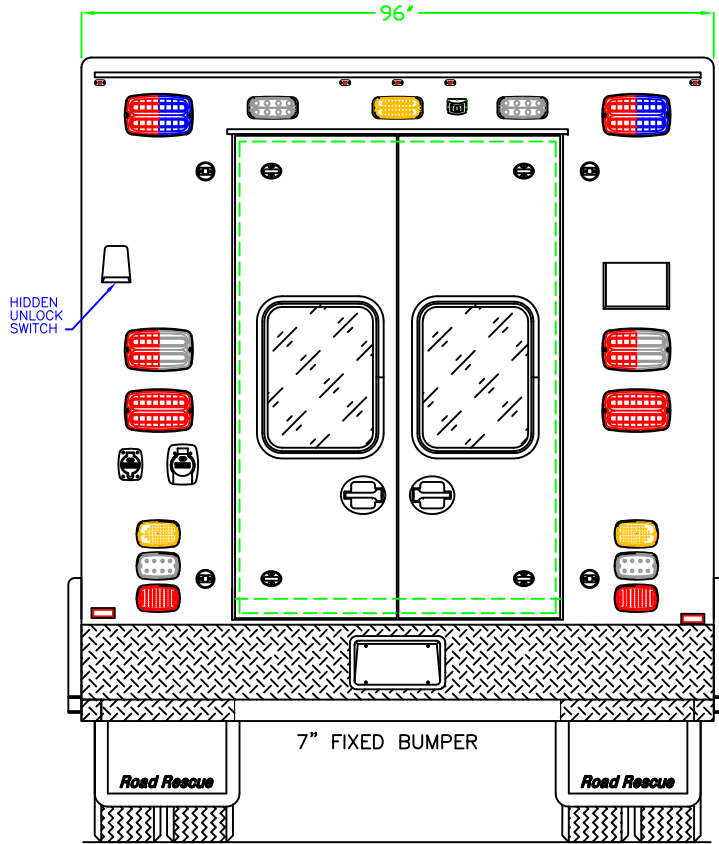

DOOR NO.	INTERIOR DIMENSIONS			NOTES
	HEIGHT	WIDTH	DEPTH	
R1	67.62"	50.25"		FIXED TINTED WINDOWS 18" X 24"



PROPRIETARY AND CONFIDENTIAL
THIS INFORMATION CONTAINED IN THIS DRAWING IS THE SOLE PROPERTY OF ROAD RESCUE INC. ANY REPRODUCTION IN PART OR AS A WHOLE WITHOUT THE WRITTEN PERMISSION OF ROAD RESCUE IS PROHIBITED.

DETAILS ARE CONCEPTUAL ONLY.
LAYOUT AND ALL DIMENSIONS ARE APPROXIMATE AND ARE SUBJECT TO MODIFICATION BY DESIGN ENGINEERING.

Road Rescue 2737 N. FORSYTH RD
WINTER PARK, FL 32792
www.roadrescue.com PHONE 800-932-7077 FAX 800-513-2688
DRAWN BY RRS DATE 06/07/2018 REVISION 1

FRONT & REAR EXTERIOR DETAIL

REVISION 2 REVISION 4 REVISION 6
SHEET 3 OF 13

BID NUMBER
 **218153** 

ODESSA FIRE DEPARTMENT FREIGHTLINER ULTRAMEDIC WALK-THROUGH

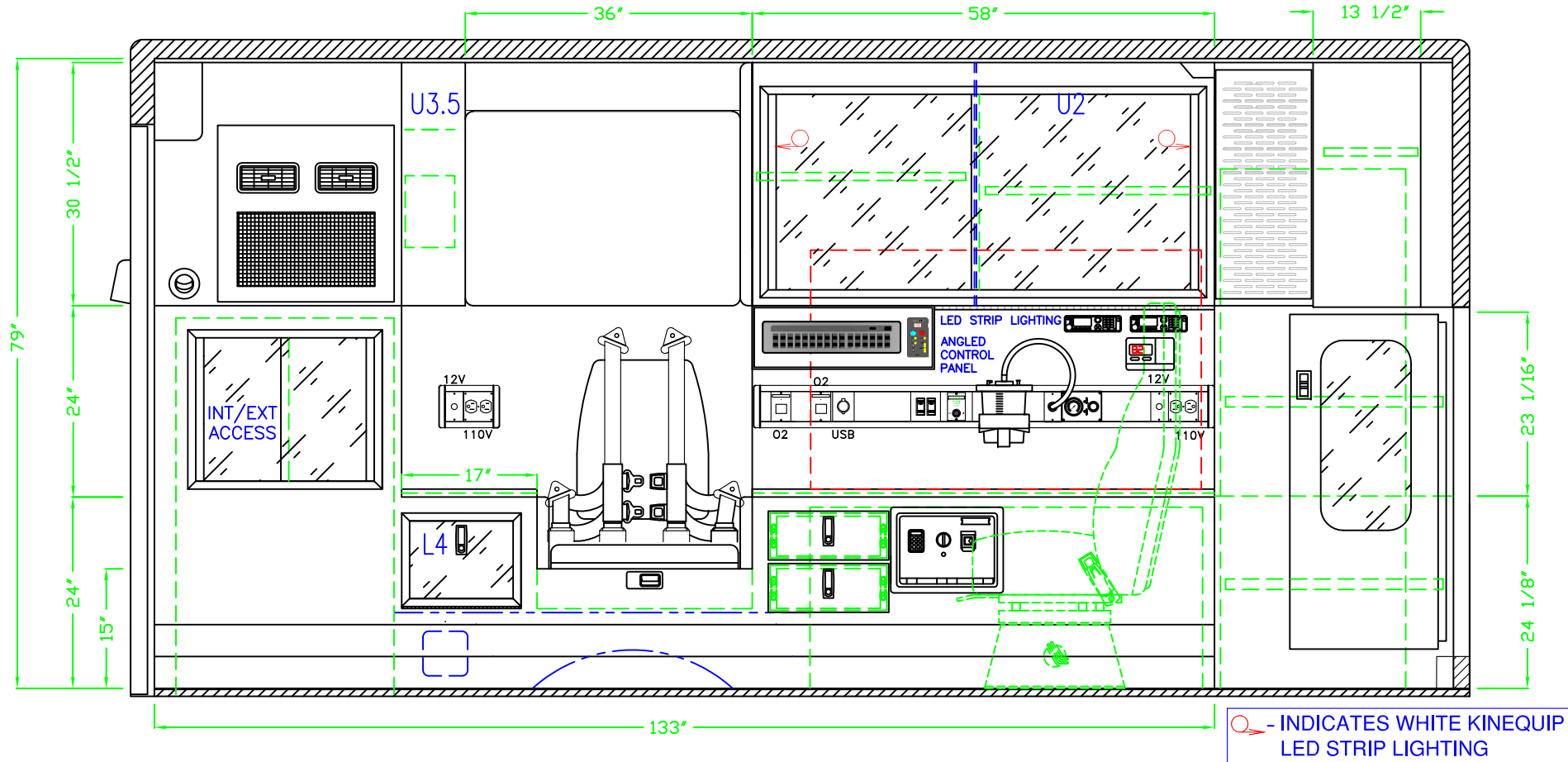

DOOR NO.	INTERIOR DIMENSIONS			NOTES	DOOR NO.	INTERIOR DIMENSIONS			NOTES
	HEIGHT	WIDTH	DEPTH			HEIGHT	WIDTH	DEPTH	
C1	23.00"	29.00"	15.50"	DOUBLE ALUM. LOCKING DOORS, (1) ADJ. SHELF	L4	12.00"	14.00"	12.00"	SINGLE FRAMED LEXAN DOOR
L1	23.50"	29.00"	15.50"	DOUBLE ALUM. DOORS, LOCKING	DETAILS ARE CONCEPTUAL ONLY. LAYOUT AND ALL DIMENSIONS ARE APPROXIMATE AND SUBJECT TO MODIFICATION BY DESIGN ENGINEERING.				
U2	30.50"	58.00"	13.50"	SLIDING PLEX DOORS, (2) ADJ. SHELVES, RESTOCK					
U3.5	30.50"	23.00"	8.00"	FRAMED LEXAN DOOR, (2) ADJ. SHELVES					

PROPRIETARY AND CONFIDENTIAL
THIS INFORMATION CONTAINED IN THIS DRAWING IS THE SOLE PROPERTY OF ROAD RESCUE INC. ANY REPRODUCTION IN PART OR AS A WHOLE WITHOUT THE WRITTEN PERMISSION OF ROAD RESCUE IS PROHIBITED.

Road Rescue

2737 N. FORSYTH RD
WINTER PARK, FL 32792



STREETSIDE INTERIOR DETAIL

BID NUMBER

www.roadrescue.com PHONE 800-932-7077 FAX 800-513-2688

DRAWN BY RRS DATE 06/07/2018 REVISION 1 REVISION 2 REVISION 4 REVISION 6

SHEET 4 OF 13

 **218153** 

ODESSA FIRE DEPARTMENT FREIGHTLINER ULTRAMEDIC WALK-THROUGH

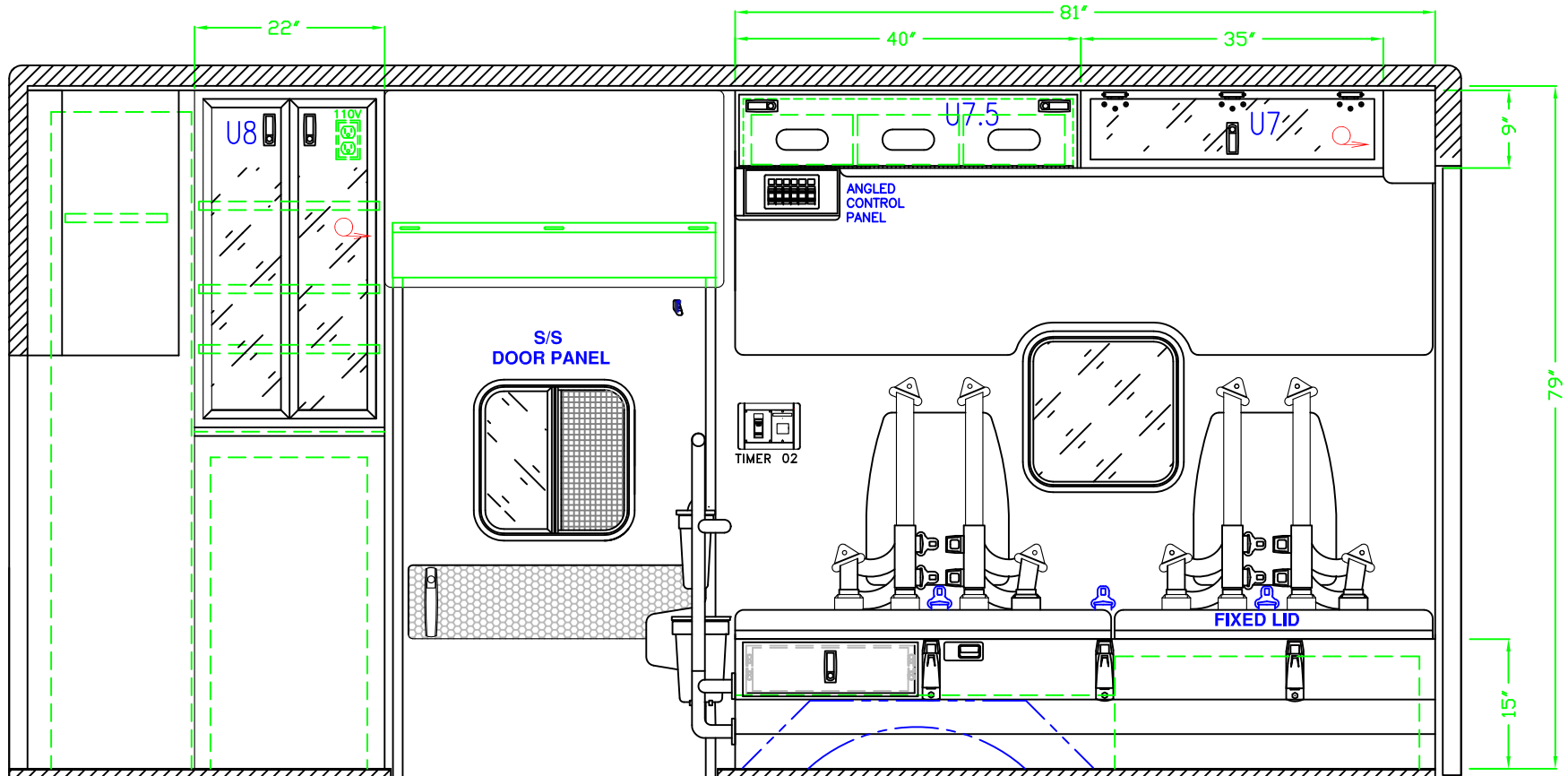

 - INDICATES WHITE KINEQUIP LED STRIP LIGHTING



DOOR NO.	INTERIOR DIMENSIONS			NOTES
	HEIGHT	WIDTH	DEPTH	
U7	9.00"	35.00"	8.50"	FLIP DOWN DOOR, GLOVE STORAGE
U7.5	9.00"	40.00"	8.50"	LIFT UP DOOR, RESTOCK
U8	40.00"	22.00"	13.00"	FRAMED LEXAN DOORS, (3) ADJ. SHELVES

PROPRIETARY AND CONFIDENTIAL
THIS INFORMATION CONTAINED IN THIS DRAWING IS THE SOLE PROPERTY OF ROAD RESCUE INC. ANY REPRODUCTION IN PART OR AS A WHOLE WITHOUT THE WRITTEN PERMISSION OF ROAD RESCUE IS PROHIBITED.

DETAILS ARE CONCEPTUAL ONLY. LAYOUT AND ALL DIMENSIONS ARE APPROXIMATE AND SUBJECT TO MODIFICATION BY DESIGN ENGINEERING.

CURBSIDE INTERIOR DETAIL

BID NUMBER

 218153 

SHEET 5 OF 13



ODESSA FIRE DEPARTMENT FREIGHTLINER ULTRAMEDIC WALK-THROUGH

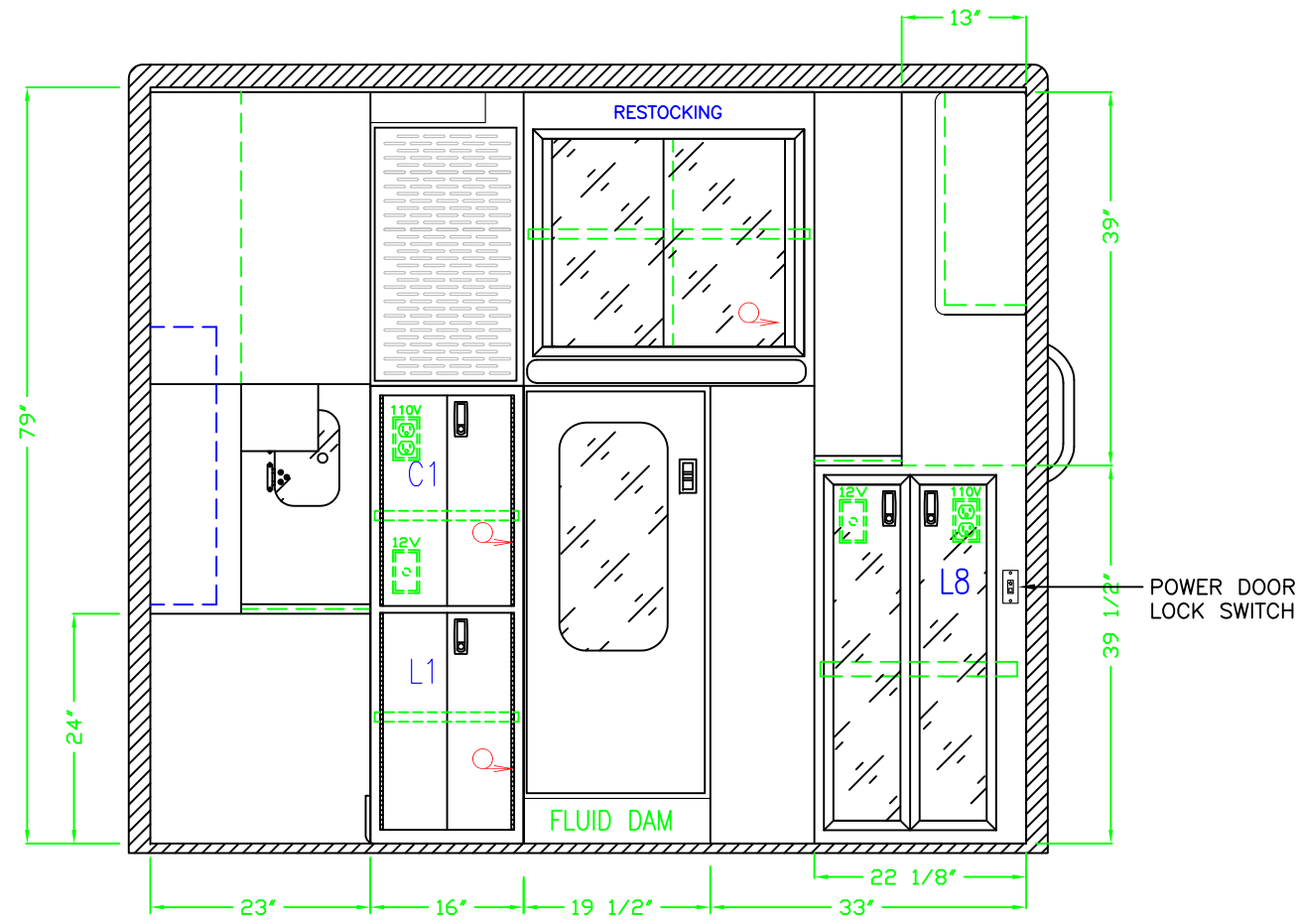

DOOR NO.	INTERIOR DIMENSIONS			MISC. NOTES
	HEIGHT	WIDTH	DEPTH	
L8	38.50"	22.00"	22.00"	DOUBLE LEXAN DOORS, (1) ADJ. SHELF

DOOR NO.	INTERIOR DIMENSIONS			NOTES
	HEIGHT	WIDTH	DEPTH	
DETAILS ARE CONCEPTUAL ONLY. LAYOUT AND ALL DIMENSIONS ARE APPROXIMATE AND SUBJECT TO MODIFICATION BY DESIGN ENGINEERING.				

PROPRIETARY AND CONFIDENTIAL
THIS INFORMATION CONTAINED IN THIS DRAWING IS THE SOLE PROPERTY OF ROAD RESCUE INC. ANY REPRODUCTION IN PART OR AS A WHOLE WITHOUT THE WRITTEN PERMISSION OF ROAD RESCUE IS PROHIBITED.

Road Rescue 2737 N. FORSYTH RD
WINTER PARK, FL 32792
www.roadrescue.com PHONE 800-932-7077 FAX 800-513-2688
DRAWN BY RRS DATE 06/07/2018 REVISION 1

FRONT INTERIOR DETAIL

BID NUMBER
218153

ODESSA FIRE DEPARTMENT FREIGHTLINER ULTRAMEDIC WALK-THROUGH

DEALER SIGNATURE 

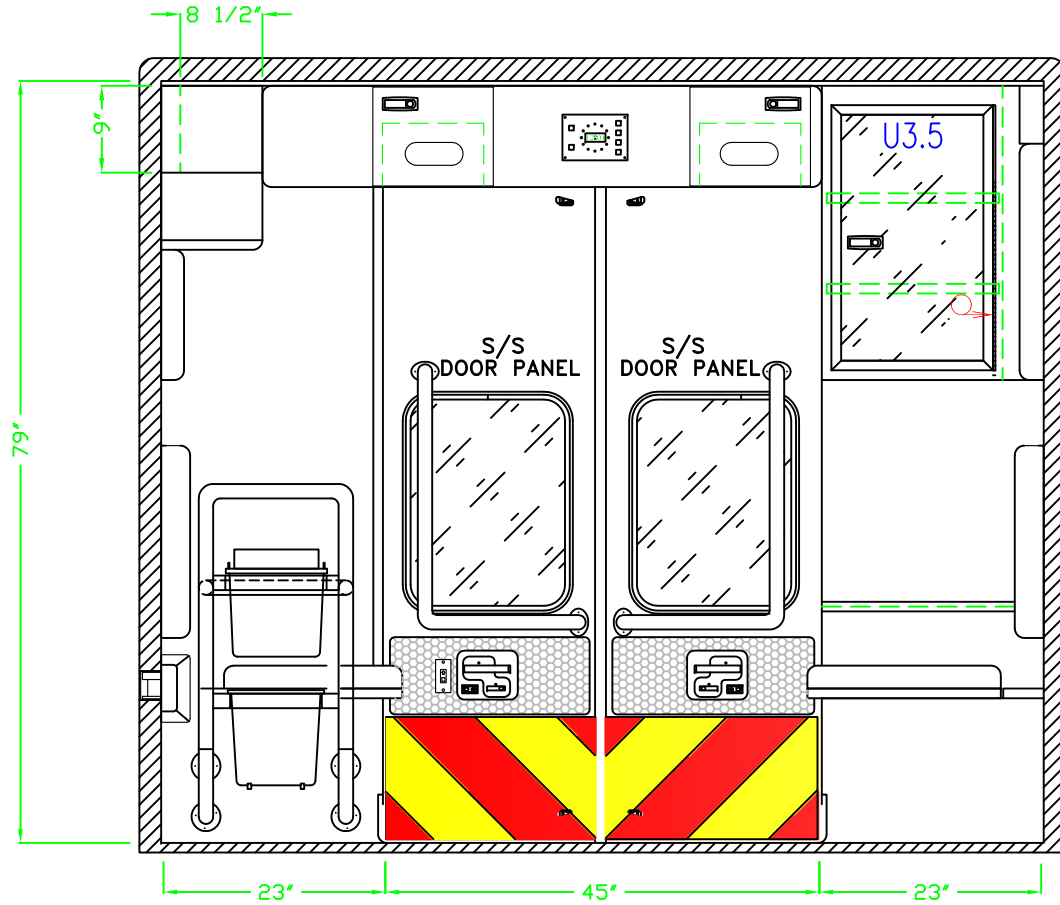



 - INDICATES WHITE KINEQUIP LED STRIP LIGHTING

DETAILS ARE CONCEPTUAL ONLY. LAYOUT AND ALL DIMENSIONS ARE APPROXIMATE AND SUBJECT TO MODIFICATION BY DESIGN ENGINEERING.

PROPRIETARY AND CONFIDENTIAL
 THIS INFORMATION CONTAINED IN THIS DRAWING IS THE SOLE PROPERTY OF ROAD RESCUE INC. ANY REPRODUCTION IN PART OR AS A WHOLE WITHOUT THE WRITTEN PERMISSION OF ROAD RESCUE IS PROHIBITED.

Road Rescue 2737 N. FORSYTH RD
 WINTER PARK, FL 32792
 www.roadrescue.com PHONE 800-932-7077 FAX 800-513-2688

REAR INTERIOR DETAIL

BID NUMBER
 **218153** 

DRAWN BY RRS	DATE 06/07/2018	REVISION 1	REVISION 2	REVISION 4	REVISION 6	SHEET 7 OF 13
-----------------	--------------------	------------	------------	------------	------------	---------------



ODESSA FIRE DEPARTMENT FREIGHTLINER ULTRAMEDIC WALK-THROUGH

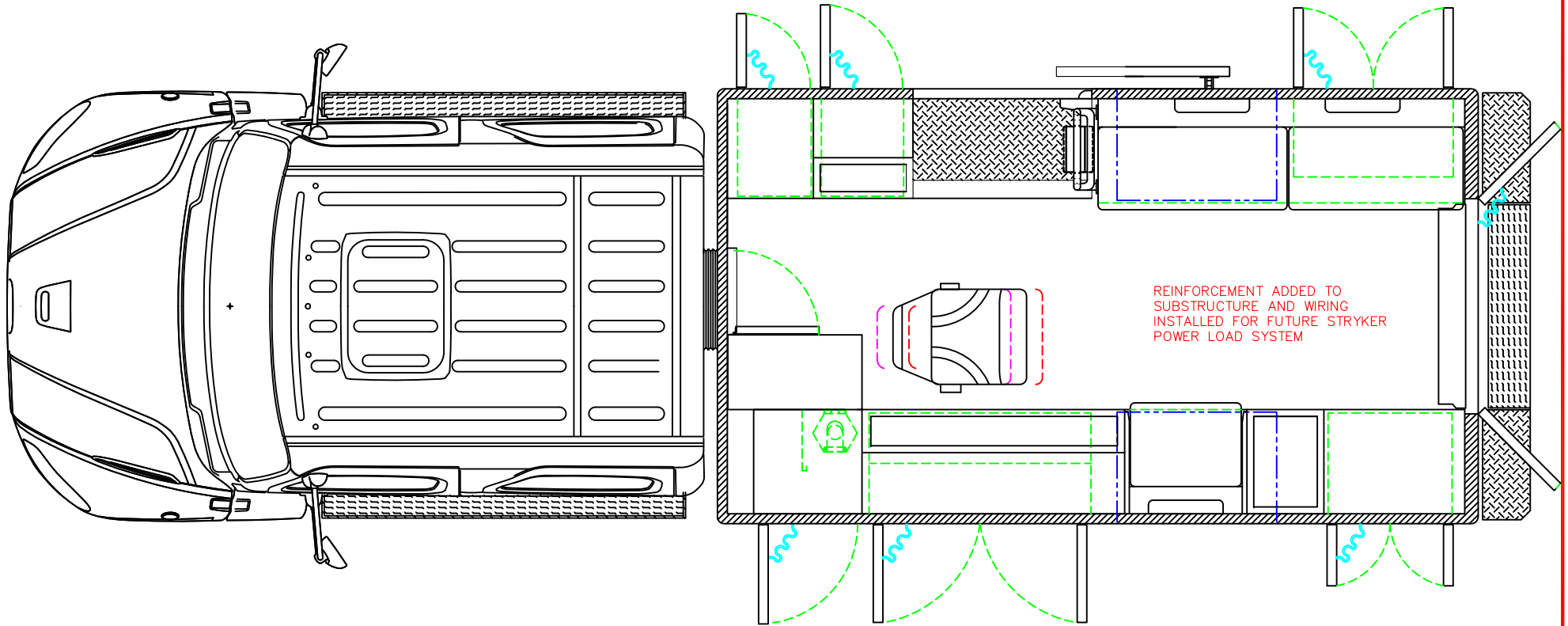

NOTES:

NOTES:

DETAILS ARE CONCEPTUAL ONLY.
LAYOUT AND ALL DIMENSIONS ARE APPROXIMATE AND
ARE SUBJECT TO MODIFICATION BY DESIGN ENGINEERING.

PROPRIETARY AND
CONFIDENTIAL
THIS INFORMATION
CONTAINED IN THIS
DRAWING IS THE SOLE
PROPERTY OF ROAD
RESCUE INC. ANY
REPRODUCTION IN PART
OR AS A WHOLE
WITHOUT THE WRITTEN
PERMISSION OF ROAD
RESCUE IS PROHIBITED.

Road Rescue 2737 N. FORSYTH RD
WINTER PARK, FL 32792

www.roadrescue.com PHONE 800-932-7077 FAX 800-513-2688

DRAWN BY RRS DATE 06/07/2018 REVISION 1

OVERHEAD FLOOR DETAIL

BID NUMBER

218153

REVISION 2 REVISION 4 REVISION 6 SHEET 8 OF 13

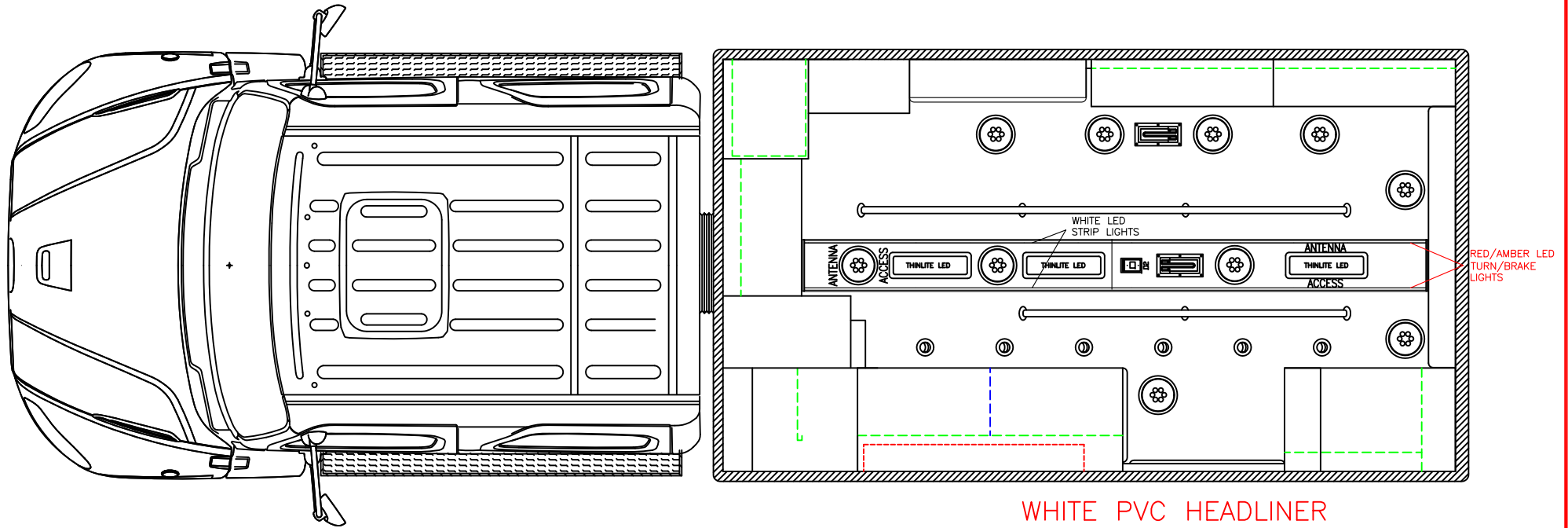

NOTES:

NOTES:

DETAILS ARE CONCEPTUAL ONLY.
LAYOUT AND ALL DIMENSIONS ARE APPROXIMATE AND
ARE SUBJECT TO MODIFICATION BY DESIGN ENGINEERING.

PROPRIETARY AND
CONFIDENTIAL
THIS INFORMATION
CONTAINED IN THIS
DRAWING IS THE SOLE
PROPERTY OF ROAD
RESCUE INC. ANY
REPRODUCTION IN PART
OR AS A WHOLE
WITHOUT THE WRITTEN
PERMISSION OF ROAD
RESCUE IS PROHIBITED.



ODESSA FIRE DEPARTMENT FREIGHTLINER ULTRAMEDIC WALK-THROUGH

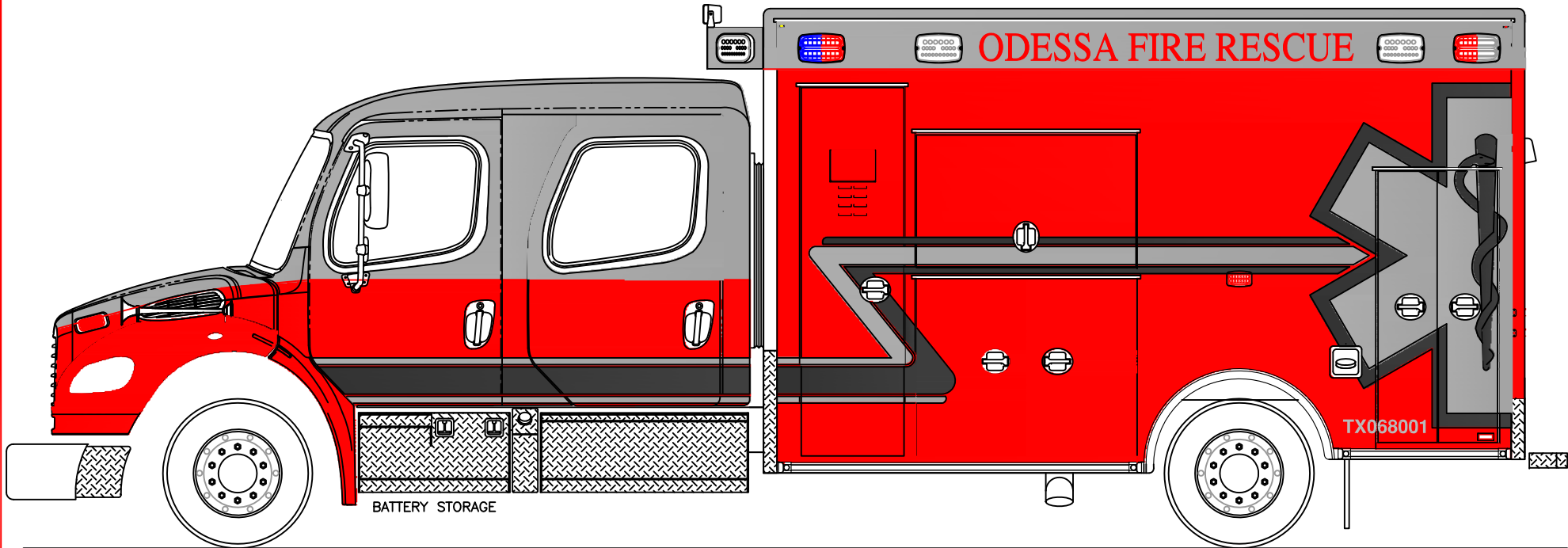

DETAILS ARE CONCEPTUAL ONLY.
LAYOUT AND ALL DIMENSIONS ARE APPROXIMATE AND
ARE SUBJECT TO MODIFICATION BY DESIGN ENGINEERING.

PROPRIETARY AND
CONFIDENTIAL
THIS INFORMATION
CONTAINED IN THIS
DRAWING IS THE SOLE
PROPERTY OF ROAD
RESCUE INC. ANY
REPRODUCTION IN PART
OR AS A WHOLE
WITHOUT THE WRITTEN
PERMISSION OF ROAD
RESCUE IS PROHIBITED.

Road Rescue 2737 N. FORSYTH RD
WINTER PARK, FL 32792
www.roadrescue.com PHONE 800-932-7077 FAX 800-513-2688

STREETSIDE EXTERIOR DETAIL

BID NUMBER



DRAWN BY RRS DATE 06/07/2018 REVISION 1

REVISION 2

REVISION 4

REVISION 6

SHEET 10 OF 13

 218153 

NOTE: THIS DRAWING IS SUBJECT TO CHANGE PENDING ROAD RESCUE, INC. PRODUCTION ENGINEERING APPROVAL. © ROAD RESCUE, INC. ALL RIGHTS RESERVED.



ODESSA FIRE DEPARTMENT FREIGHTLINER ULTRAMEDIC WALK-THROUGH



DO NOT CUT HOLES FOR COMPARTMENT LIGHTING

F - INDICATES A FULL HEIGHT KINEQUIP FLEXIBLE LIGHTING STRIP

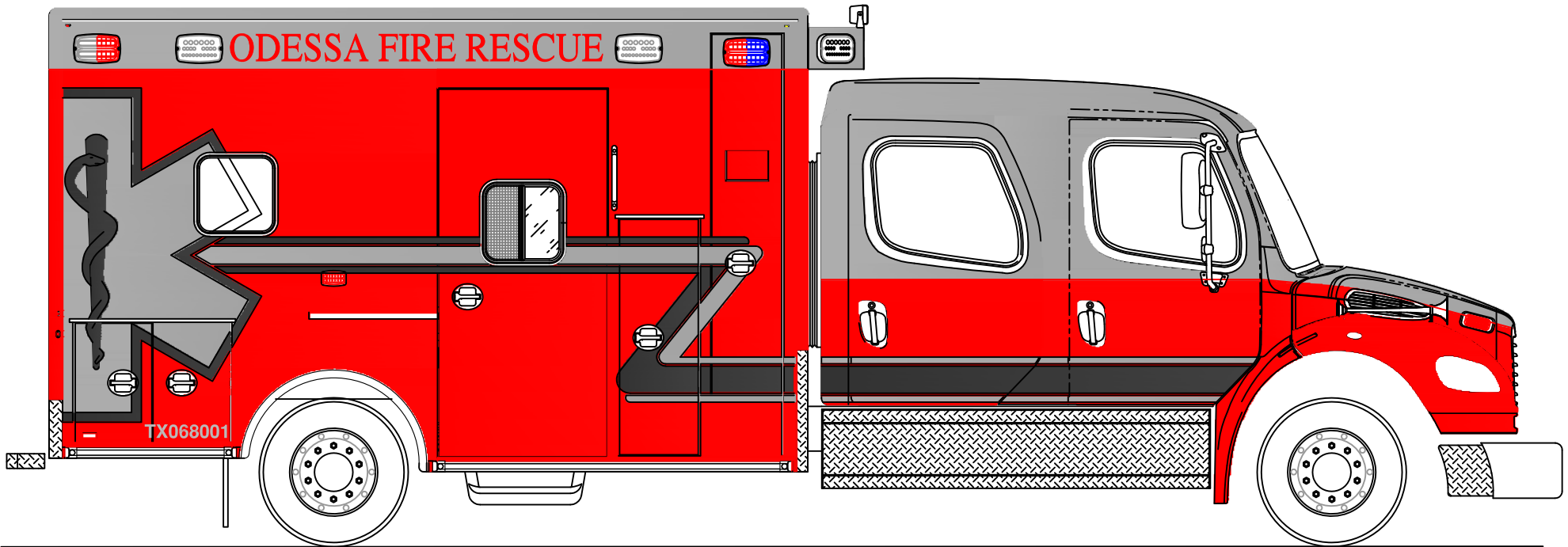

PROPRIETARY AND CONFIDENTIAL
THIS INFORMATION CONTAINED IN THIS DRAWING IS THE SOLE PROPERTY OF ROAD RESCUE INC. ANY REPRODUCTION IN PART OR AS A WHOLE WITHOUT THE WRITTEN PERMISSION OF ROAD RESCUE IS PROHIBITED.

DETAILS ARE CONCEPTUAL ONLY.
LAYOUT AND ALL DIMENSIONS ARE APPROXIMATE AND ARE SUBJECT TO MODIFICATION BY DESIGN ENGINEERING.

Road Rescue 2737 N. FORSYTH RD
WINTER PARK, FL 32792
www.roadrescue.com PHONE 800-932-7077 FAX 800-513-2688

CURBSIDE EXTERIOR DETAIL

BID NUMBER
218153

DRAWN BY RRS	DATE 06/07/2018	REVISION 1	REVISION 2	REVISION 4	REVISION 6	SHEET 11 OF 13
-----------------	--------------------	------------	------------	------------	------------	----------------

NOTE: THIS DRAWING IS SUBJECT TO CHANGE PENDING ROAD RESCUE, INC. PRODUCTION ENGINEERING APPROVAL. ©ROAD RESCUE, INC. ALL RIGHTS RESERVED.



Road Rescue
AN ALLIED SPECIALTY VEHICLE COMPANY
In Service for Life

ODESSA FIRE DEPARTMENT FREIGHTLINER ULTRAMEDIC WALK-THROUGH

DEALER SIGNATURE	
------------------	--

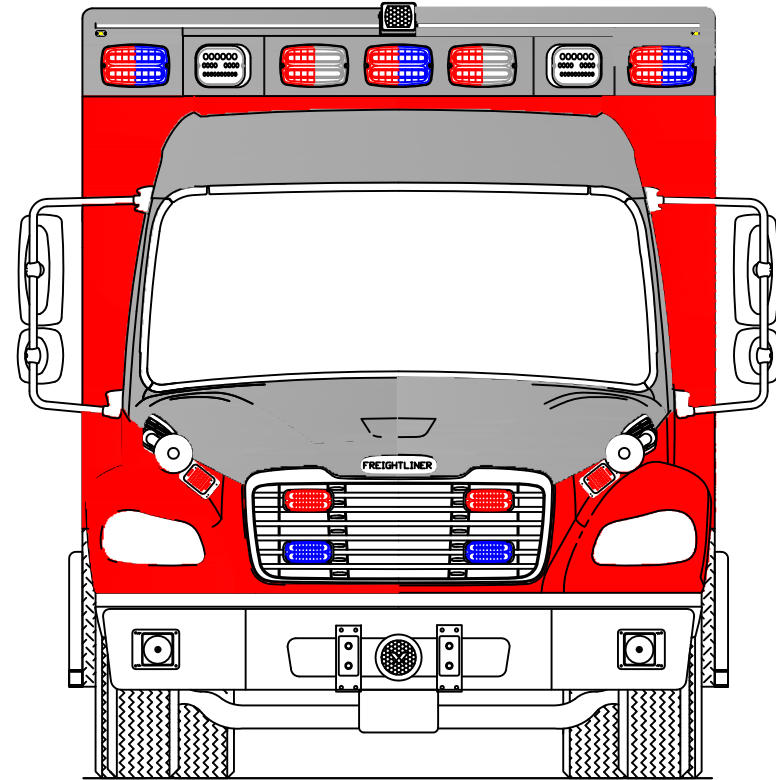
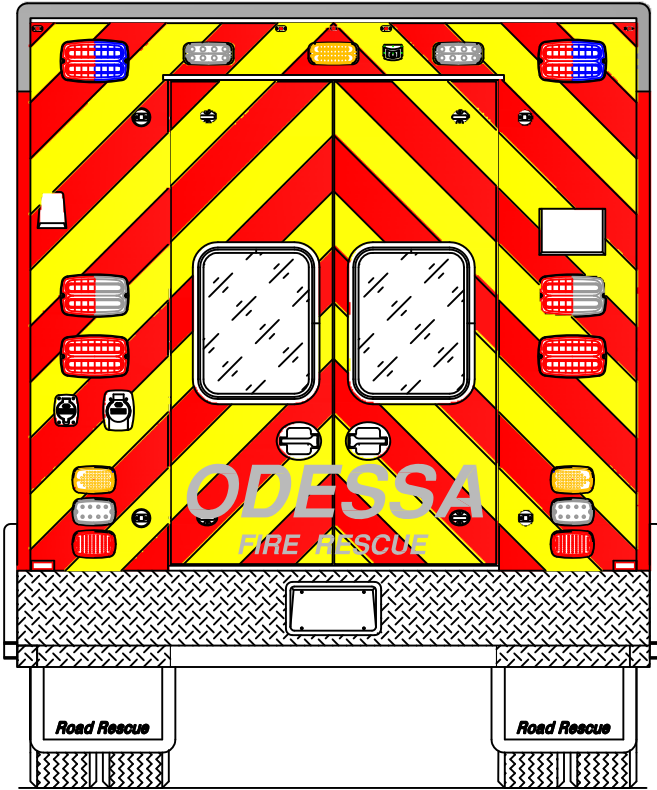

DETAILS ARE CONCEPTUAL ONLY.
 LAYOUT AND ALL DIMENSIONS ARE APPROXIMATE AND
 ARE SUBJECT TO MODIFICATION BY DESIGN ENGINEERING.

PROPRIETARY AND
 CONFIDENTIAL
 THIS INFORMATION
 CONTAINED IN THIS
 DRAWING IS THE SOLE
 PROPERTY OF ROAD
 RESCUE INC. ANY
 REPRODUCTION IN PART
 OR AS A WHOLE
 WITHOUT THE WRITTEN
 PERMISSION OF ROAD
 RESCUE IS PROHIBITED.

Road Rescue 2737 N. FORSYTH RD
 WINTER PARK, FL 32792
 www.roadrescue.com PHONE 800-932-7077 FAX 800-513-2688
 DRAWN BY RRS DATE 06/07/2018 REVISION 1

FRONT & REAR EXTERIOR DETAIL

BID NUMBER
 218153

CUSTOM CONSOLE FREIGHTLINER ULTRAMEDIC PASS-THROUGH

DEALER SIGNATURE 

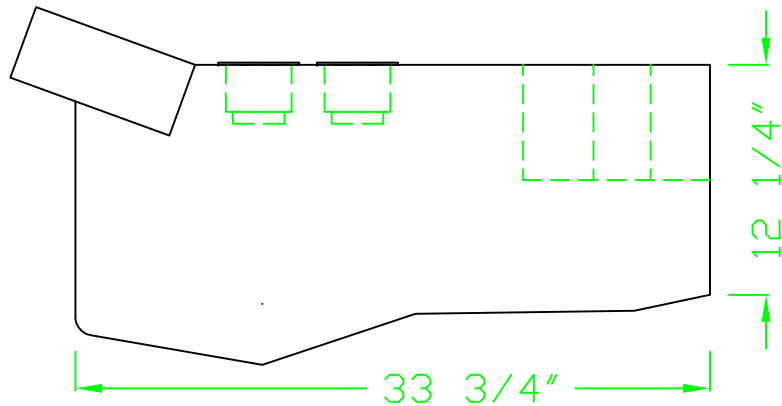

REFERENCE # 9R7207-08

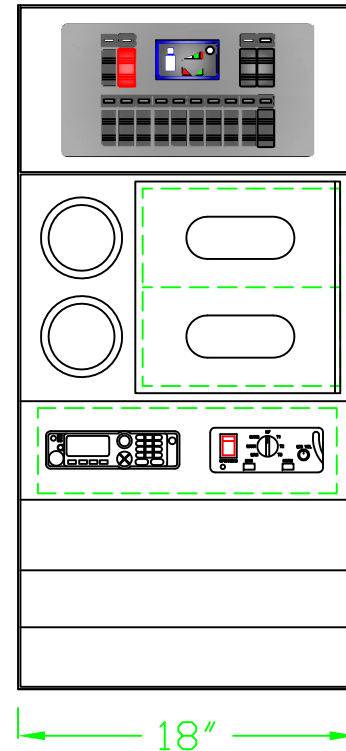

DETAILS ARE CONCEPTUAL ONLY. LAYOUT AND ALL DIMENSIONS ARE APPROXIMATE AND SUBJECT TO MODIFICATION BY DESIGN ENGINEERING.

PROPRIETARY AND CONFIDENTIAL
THIS INFORMATION CONTAINED IN THIS DRAWING IS THE SOLE PROPERTY OF ROAD RESCUE INC. ANY REPRODUCTION IN PART OR AS A WHOLE WITHOUT THE WRITTEN PERMISSION OF ROAD RESCUE IS PROHIBITED.

Road Rescue, Inc. 2914 SPARTAN PLACE
P.O. BOX 1178
MARION, SC 29571
www.roadrescue.com PHONE 843-676-2900 FAX 843-676-2997

CONSOLE CONFIGURATION

BID NUMBER

DRAWN BY	DATE	REVISION 1	REVISION 2	REVISION 3	SCALE NONE	SHEET 13 OF 13
----------	------	------------	------------	------------	---------------	----------------

